

ISOMETRIC VIEW - FRONT

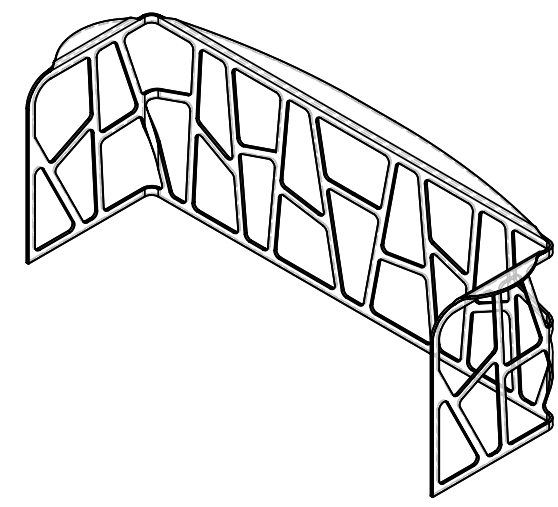

**BILL OF MATERIALS**

**BASE (x1)**  
Laser cut, bent and polished stainless steel sheet (thickness 10mm).



**BOTTOM SLAT (x1)**  
25x50mm FSC certified hardwood.



**MAIN SLAT (x12)**  
25x50mm FSC certified hardwood.



**TOP SLAT (x1)**  
25x50mm FSC certified hardwood.

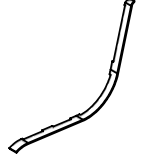

**SUPPORT PLATE - LEFT (x1)**  
30mm wide by 10mm thick stainless steel plate welded on to base for slat support.

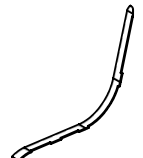

**SUPPORT PLATE - RIGHT (x1)**

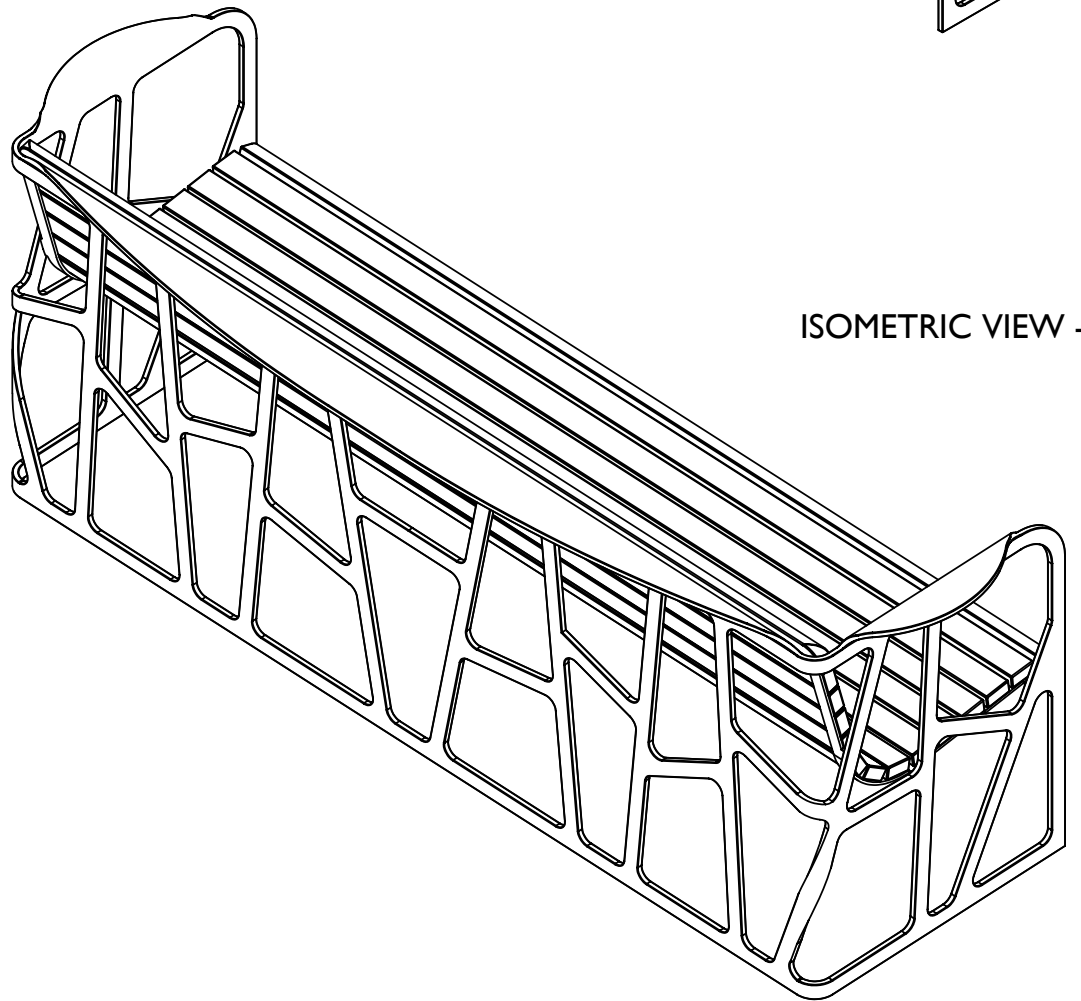

ISOMETRIC VIEW - BACK

<b>PARKLIFE</b>  Urban seating bench  6 April 2010	<b>MATERIALS</b> 1. Polished stainless steel sheet 2. Painted FSC hardwood	<b>NOT TO SCALE</b>	<b>3.pdf</b>
	<b>DIMENSIONS: mm</b>	<b>CONTACT</b> George Liarikos +44 7771658535 george@oofdesign.co.uk	